

## EVG LED 24/150 (Extra-low voltage)

### General description

Electronic transformer (EVG) converting the AC input voltage (230 V, 50/60 Hz) into a 24 V DC voltage for the operation of light emitting diodes (LEDs).

The EVG is contained in a metal housing and fully embedded in artificial resin for additional insulation. It thus corresponds to the dust and moisture protection of IP65.

Electrical connection is made by a three-core mains cable on the input side (230 V) and a two-core DC cable on the output side (24 V).

### Further device data

<u>Weight</u>	1.150 kg
<u>Standard</u>	i.a. EN61347-1, EN 61347-2-13
<u>Temperatures</u>	Ambient temperature range: -40 - +70°C
<u>Housing</u>	Anodized aluminium shell Electronics completely encapsulated
<u>Class of protection</u>	I
<u>Degree of protection</u>	IP 65
<u>Input voltage</u>	90 - 305 V AC, 47 - 63 Hz 127 - 431 V DC
<u>Input current</u>	0.75 A at 230 V mains voltage
<u>Output voltage</u>	24 V DC +/-2.5%
<u>Output current</u>	max. 6.3 A at 24 V
<u>Protection against</u>	Short-circuit, overcurrent, overvoltage, overtemperature

### Characteristic curve of the efficiency depending on the load:

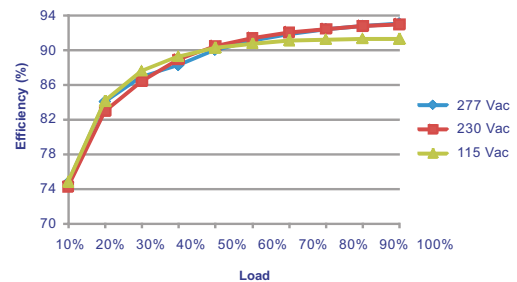

### Characteristic curve of the power reduction depending on the ambient temperature:

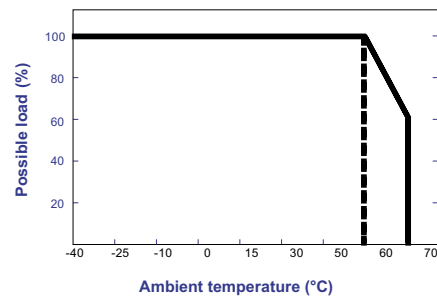

### Certification marks:

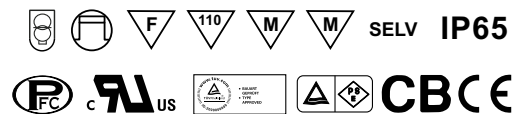

### Typical connection of LEDs on the out put side

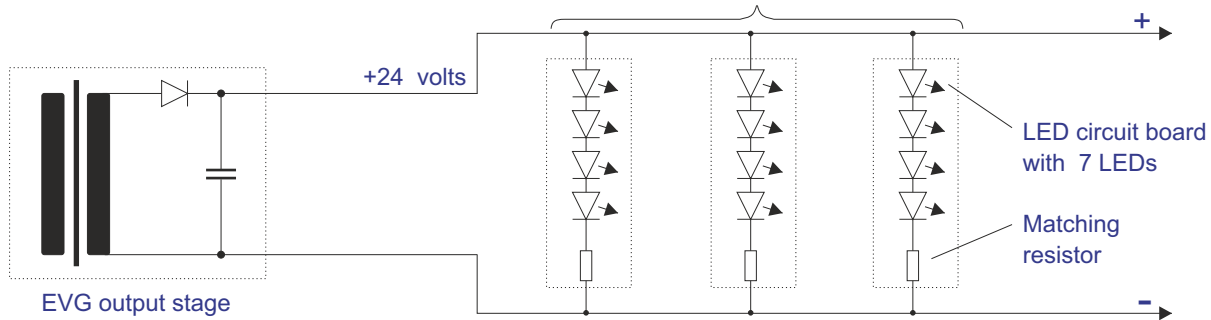

### Housing dimensions

Order no. 5 2450 150

Housing colour: silver  
All dimensions in millimetres

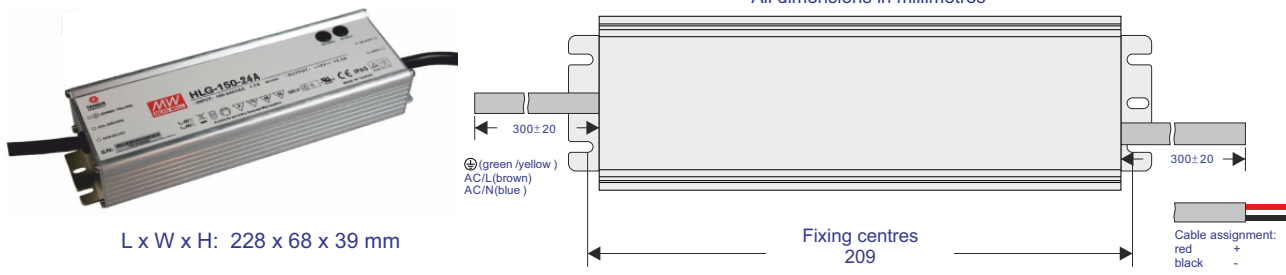

Technical modifications reserved. Content is protected by copyright.

January 2019 ELV-24-150/01/2019