

## LED Tube

### Safety notes

- The electrical connection must be carried out by qualified electricians only. Make sure that the circuit is de-energized before connecting.
- Only use original parts from the manufacturer for maintenance and repair.
- The manufacturer accepts no liability for damage caused by improper use.
- Keep these instructions with the inspection documentation.

### Intended use

- The **hansen** LED Tube is a semi-finished product which fulfills its final function after further processing (e.g. installation) by the customer or third parties.
- The LED Tube is designed for the illumination of channel letters, light boxes and similar hollow bodies inside and outside dry rooms. In addition, it can be operated "open", i.e. without protective enclosure inside dry rooms when appropriate mechanical or electrical protection is provided.
- Proper operation, storage and processing of the LED Tube is only possible in still natural air, free of chemically reactive gases, vapours, aerosols, liquids or solids, within the temperature range between -10 °C and +50 °C, at humidity levels below dew point (no condensation), free of UV radiation or ionizing radiation with wavelengths below 380 nm. Any use of the product outdoors outside suitable hollow bodies or under water is not permitted.
- Observance of the data sheet and the operating and installation instructions is part of the intended use.

### LED Tube and accessories



**1 LED Tube**

**Accessories** (picture shows example):  
not included in the scope of delivery, depends on the order, quantity and scope stated in the delivery note

- 2 LED converter (optional)**
- 3 WAGO connectors (optional)**
- 4 Insulating caps (optional)**
- 5 Tube holders (optional)**

### Unpacking and checking the content

The packaging must be opened in such a way that the content is not damaged. Particular care must be taken when using sharp tools. After unpacking, immediately check the content for damage and compliance with the delivery note. Any defects or deficiencies must be notified to us immediately.

### Shortening the LED Tube

(only possible with an LED spacing of 40 mm or more)

If the LED Tube is not to be used in its original length, it must be shortened as follows:

- Using sharp diagonal cutting pliers, cut the heat shrink tubing and the connecting wire directly at the next LED (this LED circuit board will be lost!).
- Using a suitable cable dismantling knife, carefully make a cut around the entire circumference of the heat shrink tubing approx. 30 mm from the freshly cut wire end. Doing so, make sure not to cut or damage the insulation of the connecting wire inside the heat shrink tubing.
- Pull off the loosened piece of heat shrink tubing in the axial direction.
- Now cut the insulation of the cable approx. 15 mm from the wire end around the entire circumference and pull off (strip) the insulation.

Do the same with the connecting wire on the other side of the lost LED circuit board.

### Installing the LED Tube

- The hollow body to be illuminated (illuminated letter) must be suitable for the installation of the LED tube. The back wall to which the LED tube is to be glued must be clean and free of grease. There must be one or more drainage holes present (min. 7 mm diameter).
- Depending on the distance between the LEDs, a tube holder must be attached to every 2nd to 4th LED. The first and last LED of a continuous tube should always be fitted with a tube holder.
- The tube holder is pushed over the tube on the back of the circuit board.
- The adhesive surface on the back of the letter must be clean and free of grease. Then remove the protective film from the adhesive base. After removing the protective film, ensure that the adhesive surface is not touched.
- Press the tube holder (with the LED) firmly onto the base by hand. Never use hard or sharp-edged tools or objects to do this.
- When installing the LEDs, make sure that any twisted LEDs between the tube holders are aligned straight. Ensure that the tube holder is not subjected to any tensile, compressive or torsional stress.

## LED Tube

### Connecting the LED Tube

- It must be checked whether the rated current of the LED tube matches the converter output current or is lower.
- We recommend to use two-pole screwless WAGO connectors for all electrical connections within the LED circuit. With a converter voltage above 600 volts, the terminal must be fitted with an insulating cap (type 9.5 x 30 mm, art. no. 5 0004 008).
- The insulation of the connecting cables of the LED Tube must be sufficiently stripped (over a length of approx. 15 mm) to ensure a secure contact in the WAGO connector.

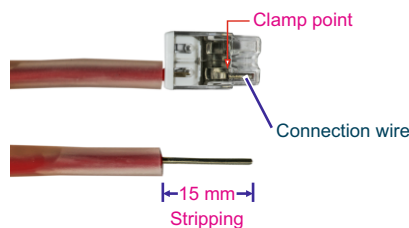

- The LEDs inside the channel letters and the channel letters themselves are connected in series, i.e. the negative “-” end of one tube section is connected to the positive “+” end of the next tube section. The polarity is marked with “+” and “-” on the rear of the circuit boards. The converters, however, are connected to the two main ends of the entire system negative “-” to negative “-” and positive “+” to positive “+”!

### Connecting one LED Tube with another:

RED (+) to BLACK (-) or vice versa

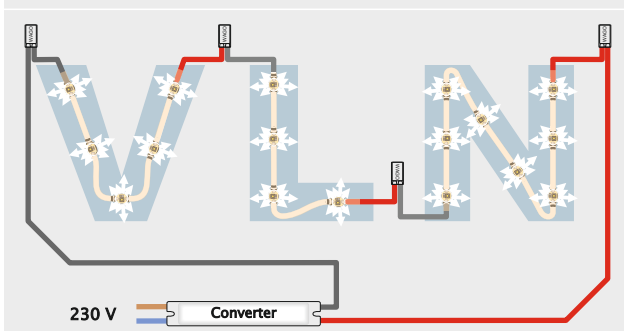

- In electrical circuits with a converter open-circuit voltage above 600 V, each WAGO connector must be provided with an additional insulating cap (article no. 5 0004 008).
- Connections between individual LED Tube sections within a channel letter must be arranged in such a way that any condensate which may collect inside the tube can drain away safely (i.e. tube openings facing downwards, connecting wires bent upwards and insulating cap fitted to the WAGO connector with the opening facing downwards).

- The connections must not be left lying directly on the bottom of the channel letter and should be protected against moisture by an insulating cap which is open at the bottom. The channel letter must be provided with drainage holes for water (e.g. condensed water).

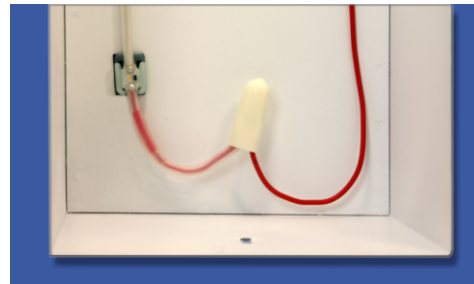

- The connection of the LEDs to the converters must only be made when the system is de-energised. Establish and check the connection between the LEDs and the converter first before switching on the mains voltage.
- The converters are connected to the two main ends of the entire system negative “-” to negative “-” and positive “+” to positive “+”!

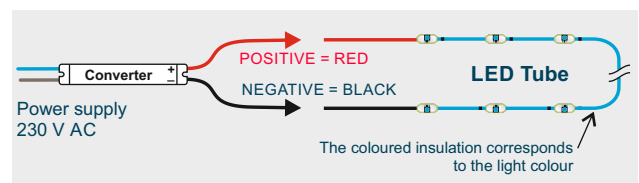

### Advice for safe and trouble-free operation

- The specified maximum number of LEDs for the converter must not be exceeded.
- The LEDs must not be operated with a current higher than the specified rated current.
- Individual sections of the LED Tube must only be connected with cables approved for the maximum open-circuit voltage of the converter used.
- The circuit must not be interrupted while the system is operational.
- For the installation of the LED converters please refer to the respective installation instructions.